

MACHINE METHODS OF ACCOUNTING

PUNCHES

THE basic principle of actuating accounting machines by completing an electrical circuit through a punched hole appearing in a strip of paper or a card made the development of an adequate card punching mechanism imperative. Such a machine was to contribute much to the inherent accuracy of the entire machine method because a permanent, unalterable, punched record could eliminate the errors due to transposition of figures and other erroneous transcriptions which occur frequently in every manual arrangement and rearrangement of accounting and statistical data. The first practical machine developed for the purpose of registering information in tabulating cards was the so-called pantograph punch.

in position on a plate to insure punching in exact predetermined positions. A punching mechanism, free to move in the plane of the card, was connected to the movable arm so that when the handle was depressed over a certain point indicated on the pantograph card chart, a hole was perforated in the corresponding position of the card. Accurate location of the hole was assured by designing the machine so that a pin under the handle had to fit into a hole drilled in the card chart before the hole in the card could be punched.

This device, although now practically obsolete, was highly successful in its adaptation to studies of the census and to vital statistics for

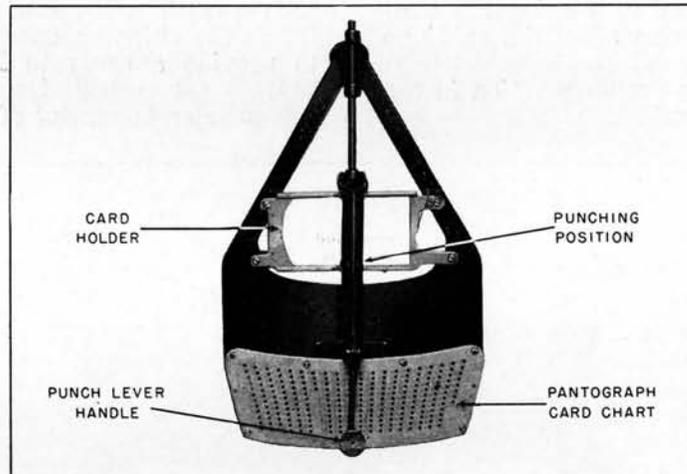

This device was so constructed that the tabulating card to be punched was accurately held

which the early tabulating machines were designed.

Mechanical Key Punch (Type 1)

The demand for the development of tabulating equipment to simplify industrial accounting routines revealed that the perforation of cards for this type of work would require a different punching mechanism. A key-driven machine, similar in principle to those which had already been developed for recording in other phases of business routines, was the obvious answer.

The Mechanical Key Punch (Type 1) was de-

veloped to record data on tabulating cards by means of a simple, compact, manually-operated, key-driven mechanism. Ruggedness of design and simplicity of operation made it an efficient and economical recording unit in many installations of the Electric Accounting Method. Although later models have superseded this type of punch, it still is widely used because of its portability, compactness, and non-electric operation.

Keyboard

This machine has twelve perforating keys, one for each punching position of a column. Ten keys are numbered from 0 to 9. The eleventh is marked "X" and punches directly above the O. It is used to record a detail or, at times, it may be arranged to cause a field to be skipped in which no information is to be punched. The twelfth key has no distinguishing mark, but punches a hole in the position directly above the "X". A space key is also provided on the upper right corner of the keyboard which, when depressed, advances the card one column without punching a hole. An additional key on the upper left corner of the keyboard, when depressed, releases the carriage for its return to the point where the card can be removed.

Operation

Each individual card is placed by the operator in the carriage of the machine prior to punching. This is accomplished by placing the card on the bed of the machine after the carriage has been released to the extreme left, and then inserting the card to its proper position in the machine by pressure against the thumb lever.

the card column punched becomes visible to the operator, permitting one to see what has been punched. Furthermore, if a card is fully inserted in the machine to start punching in column 1, the last nineteen columns of the card are visible at the right. This is especially advantageous in connection with the use of fully punched dual cards.

When necessary, more than one key may be depressed to effect simultaneous punching of two or more holes in the same column. This punch, like all numerical key punches, may be built to punch one or two identical cards in a single operation. Change from one- to two-card capacity can easily be made.

X-Skipping

The Mechanical Key Punch is provided with a means for skipping certain groups of columns, similar in function to the tabular device on a typewriter. The depression of the key marked "X", in conjunction with a special skip-bar, performs the skipping operation. It is necessary to provide a separate X-skip bar (Part No. 114702) for each design of card with different columnar arrangement of fields if, in the punch-

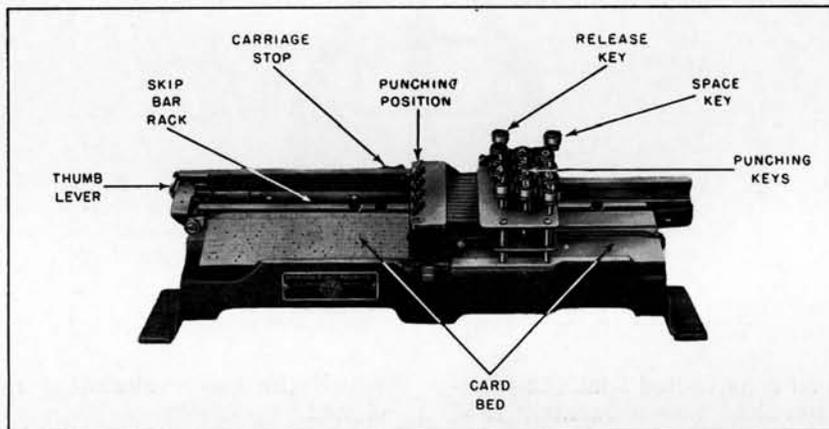

As each key is depressed the carriage automatically advances one column; except when X-skipping is effected. In that event the card may advance several columns to some predetermined point governed by the size and position of the skipped fields. When the proper information has been recorded, the operator removes the punched card, inserts another blank card, and repeats the process.

Several features have been included in the design of the machine to facilitate the punching operation. A carriage stop is provided so that punching may be begun at any column of the card. After each key has been depressed,

ing of such cards, X-skips are desired. The arrangement of skips should be carefully designated on the specification form accompanying skip-bar orders. The depression of the X-key punches a hole in the X-position of the first column of the field to be skipped.

The success of this machine established certain basic principles which have been incorporated in later improved key-punching equipment. In each successive model which has been developed, fatigue-reducing, automatic features have been added; but the compact keyboard, the method of advancing the card, and the skipping of fields have remained essentially unchanged.

Electric Key Punch (Type 11)

This machine corresponds generally in size and appearance to the Type 1 Key Punch. It has twelve punching keys, one for each of the columnar positions of the card that can be punched. The positions of the space key and release key, however, differ from those of the Mechanical Punch. On this machine the space key is below the seven-key and the release key is above the zero-key.

velops a greater punched card production. The Electric Key Punch is particularly advantageous for punching two cards at the same time, as it does not require any more effort to punch two cards than to punch one.

Electrical Energy

The Electric Key Punch operates on direct current only, either 110 or 220 volts, and consumes .50 amperes at 110 volts.

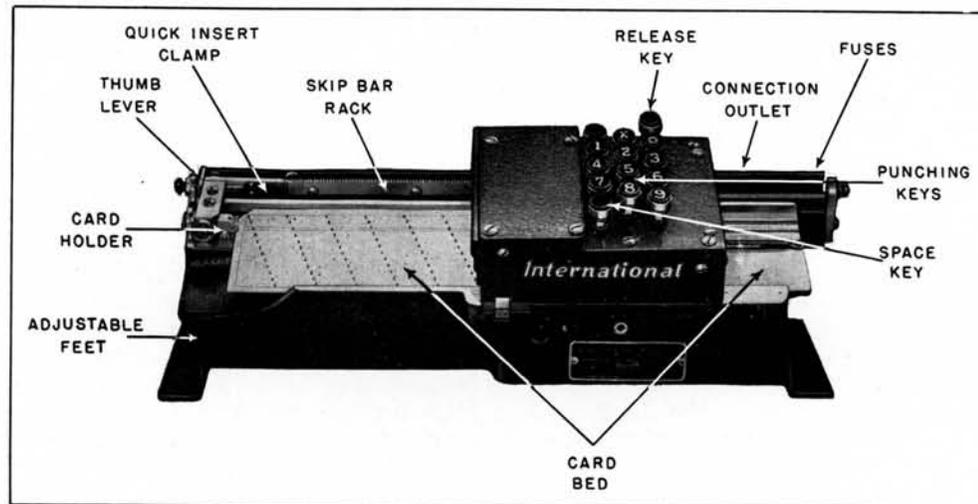

Operation

On the Electric Key Punch the holes are perforated by the action of an electro-magnet, whereas on the Mechanical Key Punch the holes are cut by manual pressure. It requires considerably less effort on the part of the operator to depress a key which merely closes an electrical contact than to exert sufficient pressure to perforate the hole in the card manually, as on the Type 1 Key Punch. It naturally follows that where less effort is required to depress the keys, the element of fatigue will be considerably reduced. As a direct consequence, the average operator is able to produce a greater volume of punched cards.

Due to the very light touch required for depressing a key, it has been found that three fingers rather than one can be used advantageously in operating the keys of this machine. When the touch system is used, the index finger operates on the first vertical row of keys—blank, 1, 4, and 7; the middle finger on the second row—X, 2, 5, and 8; the ring finger on the third row—0, 3, 6, and 9. This method decreases the hand movement, distributes the punching work over three fingers instead of one, and de-

Key Interlocking Device

The Electric Key Punch is equipped with a key interlocking device which permits the depression of only one key at a time to prevent the punching of more than one hole in a single column. As the pressure required to punch two holes would not have been perceptibly greater than that required to punch one hole, the key interlocking device was absolutely essential to prevent the accidental simultaneous depression of two keys. If it is desired to punch more than one hole in a single column, the space key may be depressed and held down while the regular numerical keys are being struck for the holes required for the column.

The key interlocking device may be made permanently inoperative, partially or in combination of individual keys.

Adjustable Base

The machine is equipped with an adjustable base, which permits placing the punch at an angle to suit the action of the operator's arm.

Electric Duplicating Key Punch (Type 12)

The reduction in operator's fatigue which accompanied the use of the Electric Key Punch and the attendant increase in card punching production disclosed the advantages which could be obtained by further developing more automatic and fatigue-reducing devices for punching equipment. The next development in the already efficient Electric Key Punching equipment was the incorporation of a duplicating mechanism. All the information contained on a tabulating card or any portion of it can be automatically reproduced on other tabulating cards by this device. Information common to more than one card can be recorded automatically; information pertaining to an individual card is recorded by the operator.

This duplicating feature is extremely useful as an automatic coding device. Master cards are prepunched with all the codes which pertain to any given set of transactions. Placing the proper master card in the duplicating rack then results in the automatic transfer of these codes in punched form to the detail cards. This not only eliminates individual coding but also expedites punching and makes verification of these codes unnecessary. The speed of the duplicating operation is approximately ten columns a second.

the keys until the automatic recording (duplication) has been completed.

Operation

A stack of unpunched cards is placed in the magazine from which the cards are fed one at a time into the punching mechanism by a hand-operated slide. The card magazine has sufficient capacity to permit loading with 300 cards at one time, thus relieving the operator of the work of frequent refilling. A paper weight is provided which properly positions the cards for feeding. This magazine constitutes an additional feature which has proven so valuable that it has been incorporated in all subsequent models of key punches. The operation of the slide adjusts the machine for punching. Cards also may be fed into the punch by hand from the left without removing or in any way disturbing those in the magazine.

As each perforation is made, the carriage automatically moves one space to the left, until all desired columns on the card have been punched. When the last column has been perforated, the operator removes the card and feeds another one into the punching mechanism by means of a hand-operated slide to repeat the process.

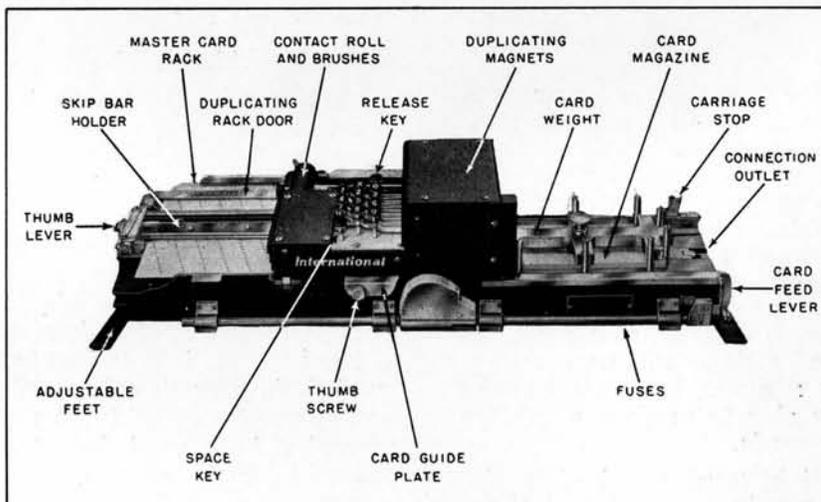

Keyboard

Whether the Duplicating Key Punch is being operated only as an Electric Key Punch, or whether the duplicating feature is being employed, the keyboard is used in the same manner as that of any other numerical key-punching machine, except that when duplicating part of a card the operator does not begin operating

Operation of the Duplicating Device

The duplicating device permits the automatic recording of repetitive data. It is actuated either by a card punched immediately preceding the employment of the duplicating feature, or by a card selected from a file containing only such data as are to be duplicated. In the first case, the first card of the group is usually punched in

its entirety, the Duplicating Punch being used as an ordinary Key Punch. In the latter, a card containing the limited required data is customarily withdrawn from a file of punched cards; it is refiled after it has served as a coding medium for the current detail cards. To transcribe automatically from either card, the card is placed in the master card bed and the door of the unit is closed by placing it down in the latched position. This raises a set of brushes which close an electrical circuit through each of the punched holes of the card on the duplicating rack in turn, and results in the automatic actuation in succession of the proper punching keys, after the card to be punched has been positioned to punch column 1. The speed of the duplicating operation permits the reproduction of all columns of an 80-column card in $7\frac{1}{2}$ seconds. All duplicated data are transcribed from specific columns of the master card to corresponding columns of the detail card. No transferral of punched data to varying columns is possible.

A duplicating cut-out stop is located directly below the duplicator table on a numbered bar. This may be placed in any position to stop duplication from a *fully* punched card at any predetermined column. Because of the operation of the cut-out stop, it is preferable to have all data to be duplicated grouped in adjacent columns and placed as near the left end of the card as possible.

Motor Drive Key Punch (Type 15)

The Motor Drive Key Punch is used to record data on tabulating cards by means of punched holes, thus preparing permanent and unalterable records for the Electric Accounting Machine Method.

As a unit of the punched card method of accounting, the punch constitutes a single simple machine capable of creating fundamental records for all phases of accounting.

The operation of this mechanism has been made as fully automatic as possible. A key-punch operator, using the machine, has no occasion to remove the right hand from the keyboard. The left hand is required only to turn pages of the original documents being transcribed. The ease with which the depression of keys is performed, combined with the elimination of all manual handling of documents, makes the use of this machine far superior to that of other methods of recording. This superiority

The device is inoperative for unpunched or double-punched columns. Unless a column is punched with a single hole, the machine will stop. This is due to the fact that when an unpunched column appears, no brush contact is made to complete the electrical circuit which effects the punching; and when a double-punched column is reached, two electrical circuits are completed, causing two keys to be simultaneously depressed, resulting in the locking of both keys by the key interlocking device.

X-skipped fields on master cards may be similarly skipped on detail cards by means of properly designed skip-bars.

Electrical Energy

The electrical requirements for this mechanism are the same as for the Electric Key Punch. It operates only on direct current, either 110 or 220 volts, and consumes .60 amperes at 110 volts. The voltage at which the machine operates may readily be interchanged. The machine may be connected to a suitable power outlet by a special cord inserted at the connection plug at the right of the machine.

Adjustable Base

This machine is also equipped with an adjustable base which permits placing the punch in a horizontal position or one of two inclined positions to attain an angle suitable to the action of the operator's arm.

includes reduction of fatigue and increase in accuracy.

Keyboard

The keyboard operation of this machine is extremely simple. It has fourteen keys, twelve of them corresponding to the twelve punching positions in each column of the card, a space key to advance the card one column without punching, and a release key to advance the card from any column to a position from which it may readily be removed.

Operation

In this machine the holes are perforated by the action of an electromagnet, which is governed by the closing of an electrical contact by the depression of a key. It naturally follows that very little effort is required and that three fingers can advantageously be used to utilize

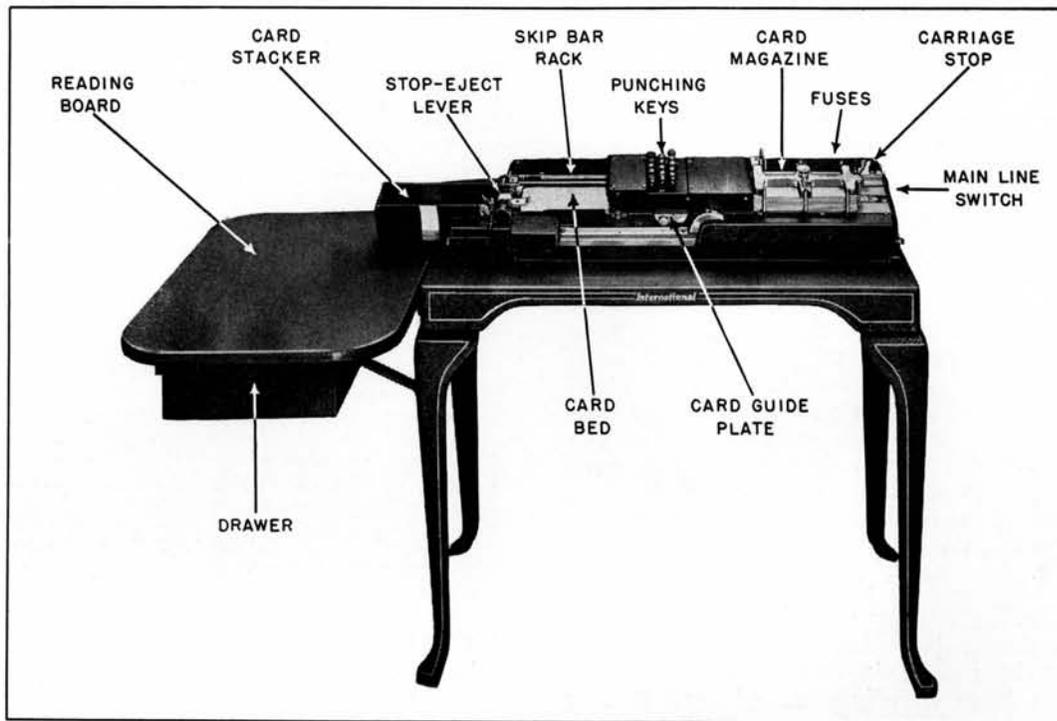

the touch system of operation. When the touch system is used, the index finger operates on the first vertical row of keys—blank, 1, 4, and 7; the middle finger, the second row—X, 2, 5, and 8; and the ring finger, the third row—0, 3, 6, and 9. This method decreases the hand movement, distributes the punching work over three fingers, and develops greater punched card production. As each punching key is depressed, the card is automatically advanced to the next punching position, and the column just punched becomes visible, thus permitting the operator to see what has been recorded.

The punch is equipped with automatic card feeding and card ejecting devices, which are so arranged that after a punched card has been ejected, a card from the magazine is automatically fed into the punching position. Cards may also be fed into the punch by hand from the left without removing or in any way disturbing those in the magazine. This manual feeding can be accomplished only after making the automatic feeding mechanism inoperative by raising the small lever at the left of the card bed. Motor drive key punches are built to punch simultaneously two cards which have been manually fed, but to punch only one card at a time if automatic feeding is employed.

For the convenience of the operator, the punch is mounted at the proper punching angle on a sturdy steel table. A reading board at the left of the punch provides a convenient place for the original records from which the data are to be transferred. It is equipped with a drawer for the operator's use. Another drawer, which can be conveniently removed from the rear of the machine, is furnished to catch the paper chips as they are perforated from the cards in the punching operation. The card magazine has sufficient capacity to permit loading with 300 cards at one time, thus relieving the operator of the work of frequent refilling. A paper weight is provided which properly positions the cards for feeding.

Key Interlocking Device

The Motor Drive Key Punch is equipped with a key interlocking device which prevents the accidental punching of more than one hole in a single column. If it is desired to punch more than one hole in a single column, the space key may be depressed and held down while the regular numerical keys are being struck for the holes required for the column. This key interlocking device may be made permanently inoperative for certain keys or combination of keys.

X-Skipping

This type of punch is provided with a means for skipping certain groups of columns, similar in function to a tabular device on a typewriter. The key marked "X", operating in connection with an especially cut skip bar, operates this mechanism. It is necessary to provide a separate X-skip bar (Part No. 114702) for each design of card with different columnar arrangement of fields if this type of skipping is to be employed. The arrangement of skips should be carefully designated on the specification form accompanying skip bar orders. The depression of the "X" key punches a hole in the X-position of the first column of the field being skipped.

The Motor Drive Key Punch may be equipped with the quick detachable X-skip bar just described or with an automatic high bar (Part No. 114706). The automatic skip or high bar is used to position the card automatically at the proper column for punching, without the necessity of depressing a key as in X-skipping.

Automatic Feeding and Ejecting

The punch is equipped with an automatic magazine feeding and ejecting device. It operates in such a way that after one punched card is automatically ejected, a blank card from the magazine is automatically fed into position for punching. The ejecting and feeding cycle consumes only 0.65 seconds.

The recently manufactured Motor Drive Key Punches automatically eject cards immediately after their last column is punched. Earlier machines are equipped with two switches marked "Release Key Eject" and "Automatic

Eject." When it is desired to punch a single hole in the last column of a card and then have it eject automatically, the "Automatic Eject" switch should be in the "on" position and the "Release Key Eject" in the "off" position. When it is desired to eject and feed cards automatically without punching a hole in the last column, both switches should be in the "on" position. When double punching (more than one hole) is desired in the last column of the card, both switches should be in the "off" position. After the key for the last hole is depressed, the space key should be depressed and the card will be automatically ejected. With machines not having the switches, multiple-punchings in the last column may be accomplished by holding down the space key while making desired recordings. If it is desired to use the machine as a straight Electric Key Punch and to have the feed and eject mechanism inoperative, both switches should be in the "off" position and the latch at the left of the machine should be raised to lock the card gripper jaws in a horizontal position.

Electrical Energy

The machine operates on direct current only, either 110 or 220 volts; and consumes .70 amperes at 110 volts. The voltage on which the mechanism will be operative may be readily changed from 110 to 220, or vice versa, to meet changes of available currents.

A connection cord equipped with a suitable terminal plug is furnished to facilitate the attachment of the machine to the available power outlets. A main line switch is provided on the right of the base to make the device operative.

Motor Drive Duplicating Key Punch (Type 16)

The automatic method of feeding and ejecting cards proved readily adaptable to a punching machine equipped with a duplicating mechanism. The Motor Drive Duplicating Key Punch is essentially similar in appearance and operation to the Motor Drive Key Punch; but the incorporation of the duplicating device permits the automatic transcription of common data to more than one card, and the subsequent manual recording by an operator of specific detail pertaining to an individual card.

All, or any portion, of the punched data appearing in a tabulating card can be automatically reproduced in other tabulating cards by this device at a speed of ten columns a second. When

the duplicating feature is not in use, the machine functions exactly like the Motor Drive Key Punch.

This duplicating feature is extremely useful as an automatic coding device. Master cards may be prepunched with all the codes pertaining to any given set of transactions and held in a file. When desired, the proper master card for any transaction may then be selected from the file and placed in the master card bed of the duplicating punch to effect the automatic transfer of these codes in punched form to the detail cards.

The duplicating feature in combination with

master code cards can effectively be used to replace four distinct manual operations.

1. The coding of original documents.
2. The verification of the accuracy of the transcription of the code to the documents.
3. The repetitive punching of common data.
4. The verification of the accuracy of punching.

The duplicating feature is also extremely valuable for reproducing cards which may have become mutilated by excessive or improper handling. The automatic duplicating mechanism serves as a medium for the accurate and rapid transcription of data from the damaged card to the new tabulating card which is to replace it.

Keyboard

Whether the Motor Drive Duplicating Key Punch is being used for duplication or as a regular Motor Drive Key Punch, the keyboard is used in the same manner as that of any other numerical key punch, except that when duplicating part of a card the operator does not start depressing the keys until the automatic recording (duplication) has been completed.

Operation of the Duplicating Device

The card from which data are to be tran-

scribed is placed in the master card bed, and the duplicating door is closed by pushing it down to the latched position. This raises a set of brushes that will complete an electrical circuit through the punched hole appearing in each column of the master card and results in the automatic successive operation of the proper punching keys, after the card to be punched has been fed into the machine. The speed of duplication permits the reproduction of all columns of an 80-column card in 7.5 to 8 seconds.

All duplicated data are transcribed from a column of the master card to the corresponding column of the detail card. No transferral of punched data to other columns is possible.

A duplicating cut-out stop is located directly below the duplicator master card bed on a numbered bar. This may be placed in any position to stop duplication from a *fully* punched card at any predetermined column. No duplication can be effected to the right of the column on which the cut-out stop is set. Because of this operation of the cut-out stop, it is preferable to have all data to be duplicated grouped in adjacent columns, and placed as near the left end of the card as possible.

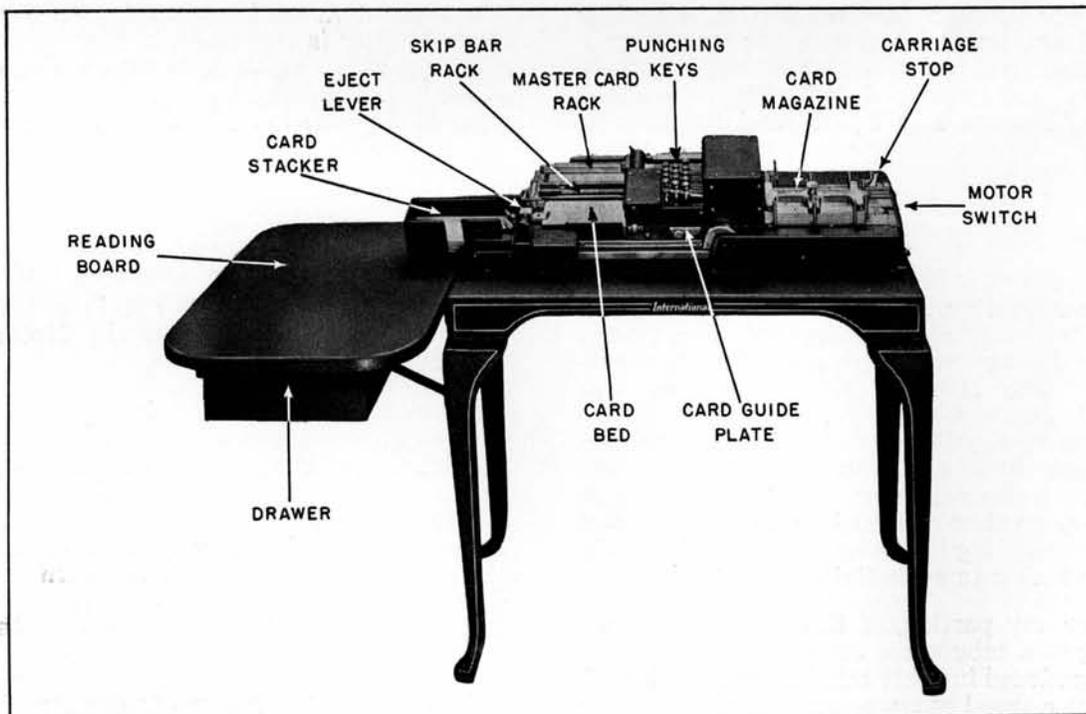

Selective duplication from a fully punched card in the master card rack is effected by means of a predetermined duplicating cut-out bar (Part No. 114710). This bar permits the manual punching of non-repetitive data in fields which are interspersed among the fields to be duplicated from a fully punched master card.

The predetermined duplicating cut-out bar is mounted in a horizontal position on the front of the master card bed. It is held in position

The duplicating device is inoperative for unpunched or double-punched columns. Unless a column is punched with a single hole the machine will stop. This is due to the fact that when an unpunched column appears, no brush contact is made to complete the electrical circuit which effects the punching; and when a double-punched column is reached, two electrical circuits are completed, causing two keys to be simultaneously depressed, resulting in the locking of both keys by the key interlocking device.

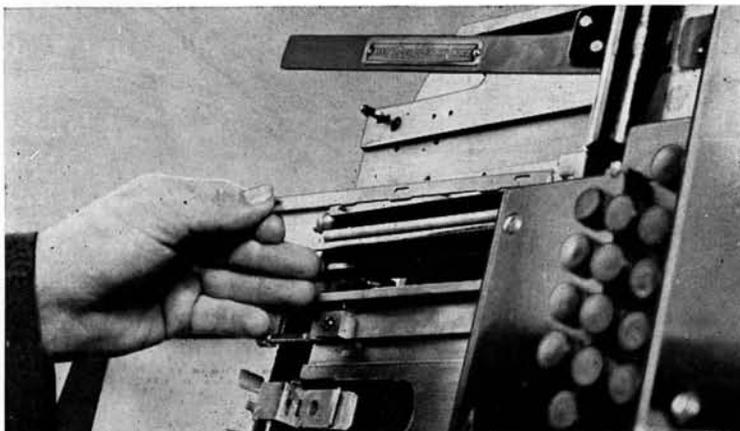

Inserting Duplicating Cut-Out Bar

by three studs and a clip. Each wide section of the bar breaks the duplicating circuit mechanically to permit the manual transcription of data to detail cards. When the column corresponding to a narrow section of the bar is reached, the duplicating circuit is re-established and automatic punching is resumed.

X-skipped fields on master cards may be similarly skipped on detail cards by means of properly designed skip-bars.

General

The general operation of this machine (excluding the duplicating feature) is identical with that of the Motor Drive Key Punch.

Alphabetic Duplicating Key Punch (Type 31)

The Alphabetic Duplicating Key Punch not only can perform all of the functions of the Motor Drive Duplicating Key Punch; but in addition it is capable of recording alphabetic information in tabulating cards in such a manner that complete words and names, together with numerical data, can subsequently be printed by the Alphabetic Accounting Machine. The accounting machine operation necessitates the punching of two holes in a single column of the card if the printing of an alphabetic character is to be effected. Consequently, a special punch was designed that would accomplish this type of recording economically and accurately. The multiple-punching in the columns of the illustrated card causes the accounting machine to print the description shown on the report form.

The two holes appearing in each column of the alphabetic description are punched simultaneously by the depression of a single alphabetic key.

Keyboard

The punching mechanism is controlled by two keyboards, one of which has both alphabetic and numerical keys arranged to correspond with those of a typewriter. The other is the same as the keyboard of a numerical key punch and is provided for convenience of operation and the attainment of maximum production.

When the alphabetic and numerical data to be punched are closely interspersed, the exclusive use of the alphabetic keyboard is most

PRODUCT		UNIT PRICE	GROSS BILLING	DISCOUNT	NET BILLING	CUSTOMER		DATE	QUANTITY	ALPHABETIC DESCRIPTION	
UNIT	ITEM					UNIT	CITY NO	DAY			
0	0	0	0	0	0	0	0	0	0	0	0
1	1	1	1	1	1	1	1	1	1	1	1
2	2	2	2	2	2	2	2	2	2	2	2
3	3	3	3	3	3	3	3	3	3	3	3
4	4	4	4	4	4	4	4	4	4	4	4
5	5	5	5	5	5	5	5	5	5	5	5
6	6	6	6	6	6	6	6	6	6	6	6
7	7	7	7	7	7	7	7	7	7	7	7
8	8	8	8	8	8	8	8	8	8	8	8
9	9	9	9	9	9	9	9	9	9	9	9

BILLING AND SALES ANALYSIS			
PRODUCT NAME	GROSS BILLING	DISCOUNT	NET BILLING
ALUMINUM CHLORIDE	3913.60	728.40	3185.20
CITRIC ACID	453.45	27.21	426.24
CODEINE SULPHATE	452.76	27.137	425.139

advantageous. When a considerable amount of numerical punching is to be performed by an operator who has been trained in the operation of numerical key-punching equipment, it is possible to attain greater speed by the use of the auxiliary numerical keyboard.

The keys of both keyboards are interlocked to prevent the accidental simultaneous depression of two keys. This precaution was essential, since the pressure required for the operation of a key is only approximately two ounces—or less than one fifth of the pressure required for the operation of an ordinary typewriter key.

Alphabetic Keyboard

The keyboard illustrated below shows the position of the various keys, most of which are self-explanatory. The numerical keys on the alphabetic keyboard perform exactly the same function as those of the numerical keyboard. They are provided on both keyboards only for convenience in operation. The skip-key operates in conjunction with a skip-bar; but does not punch a hole in the card as it does on numerical punches. The release key causes the machine to shift the card into position for automatic ejection. The "ST" key is used to eject the card.

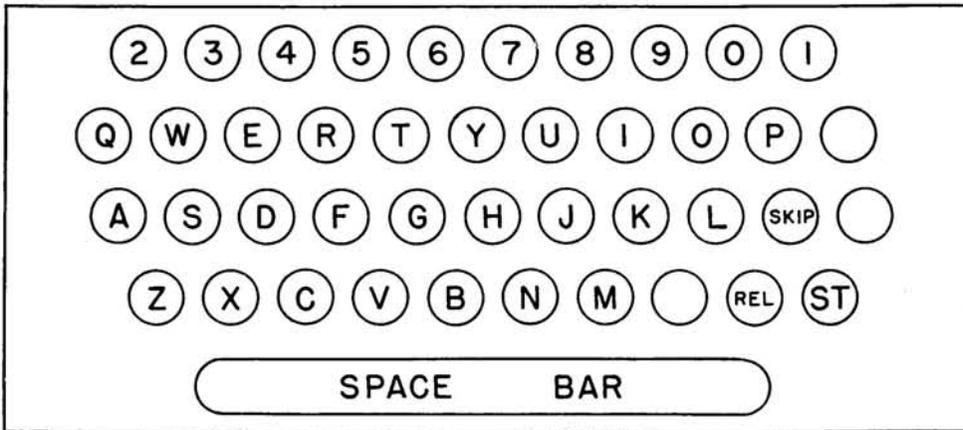

Other keys which are non-operative dummy keys are retained so that the keyboard will be identical with that of a standard typewriter to facilitate the use of the touch system on this machine by experienced typists.

Numerical Keyboard

The numerical keyboard is identical in appearance and operation with the keyboard of the numerical punches; except that the "X" key will punch a hole, but will not cause the machine to skip. Skipping must be effected by the use of the special key on the typewriter keyboard.

Operation

The operation of the Alphabetic Duplicating Key Punch is practically the same as that of a standard typewriter. The actual punching is performed as on other motor-driven punches. The incorporation of two keyboards provides a means of adapting the machine to various types of recording with a maximum of speed and accuracy.

Operation of Duplicating Mechanisms

The duplicating operation is performed in the same manner as on the Motor Drive Duplicating Key Punch. However, two holes appearing in a single column can be duplicated; or each unpunched column may be spaced over if desired. Although the keyboard is equipped with a key-interlocking device, which prevents manual multiple recording, the necessary alphabetic double punching is accomplished by depression of alphabetic keys or by duplication from a master card.

Spacing over unpunched columns automatically is controlled by an automatic space switch. When this switch is off the machine will stop when an unpunched column is reached; when on, the machine will space over unpunched single columns or skipped fields. This automatic spacing may be stopped at any predetermined column by setting the duplicating cut-out stop.

General

The Alphabetic Duplicating Key Punch is furnished only for punching 80-column cards.

It operates only on direct current, 110 or 220 volts, and consumes .70 amperes at 110 volts.

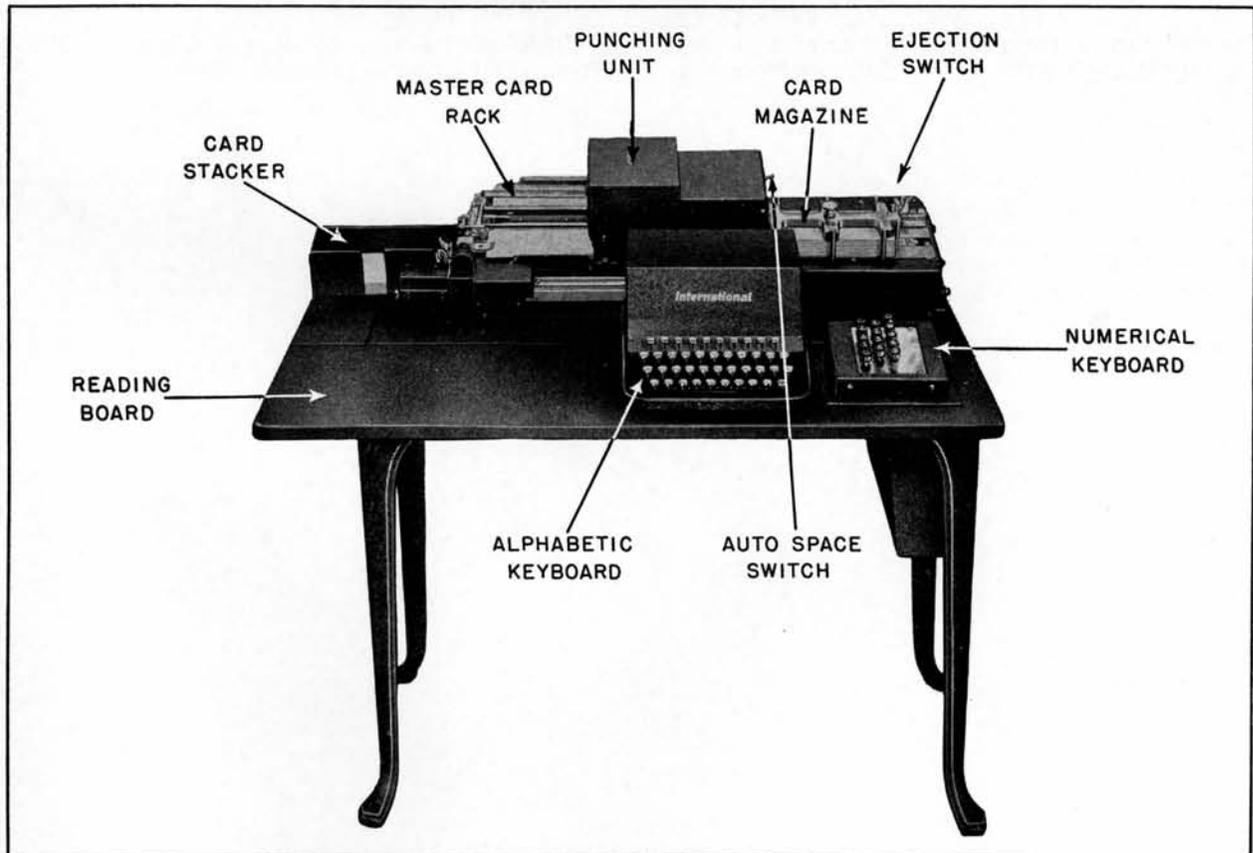

Special Devices for Punches

Card Reversing Device

The card reversing device is a special type of ejecting mechanism for automatic electric punches which reverses the order of ejected cards so that they are in the proper sequence for verifying by the Type 52 Motor Drive Verifier. After being punched, the cards are ejected into a temporary stacker face down as in the normal operation. They are then reversed and placed face up in a second card stacker, thus arranging them in the desired sequence.

When the reversing operation is not required, the device is disengaged by a clutch. The use of the device does not affect the operation of the punch in any other way.

It can be installed on Type 15 Motor Drive Key Punches and Type 16 Motor Drive Duplicating Key Punches.

Copy Racks for Punches

Motor drive punches and verifiers may be equipped with copy racks, for the support of papers, cards, etc., when so desired by the customer.

The copy rack is approximately 24" x 16" in size and can be mounted in either of two positions by changing the angle of the end brackets

connected to the punch base. The first position, illustrated below, is suitable for holding original documents during punching or for

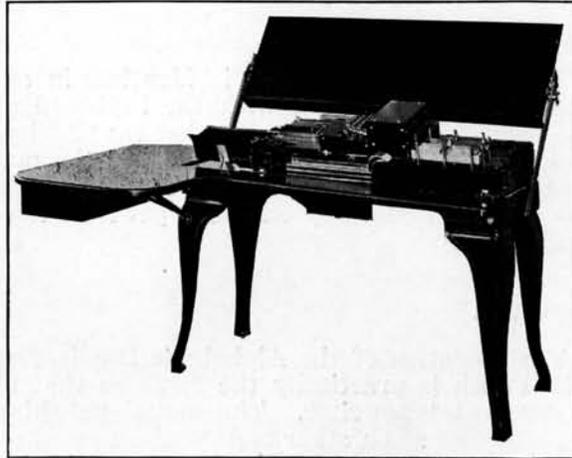

reference. The second arrangement is lower, with the rack in a horizontal position, for holding cards, etc. In either position, the slope of the rack can be readily adjusted by the use of the wing nuts at the ends.

This device can be installed on all Motor Drive Key Punches and Verifiers.